



**ENVASES SANZ BELDA, S.L.**

Tel.: 34 96 236 02 32 - calidad@envasesanzbelda.es - www.envasesanzbelda.es  
Pol. Ind. San José. Avda, Valencia, parc. 7 - Apdo. de Correos 46 - 46812 Aielo de Malferit. Valencia. (España)



## Technical comercial data

# S.N-16-P T.S.N-16

Serie SUPREMA NOVA – Versión 21-02-2024

### TECHNICAL DATA:

Material:	PP copolymer of first quality, suitable for contact with food according to current regulations.
Colours:	White standard. Consult for other colours.
Useful Volume:	16.5 litres
Volume to the edge:	17.8 litres
Weight of the bucket:	542 g. approx.
Weight of the lid:	152 g. approx.
Weight of the handle (plastic):	35 g. approx.
Total Weight:	729 g. approx.
Decorative surface flat inks:	210 x 873 mm (height x perimeter)
Design surface photographic finish:	220 x 895 mm (height x perimeter)



### MEASUREMENTS:

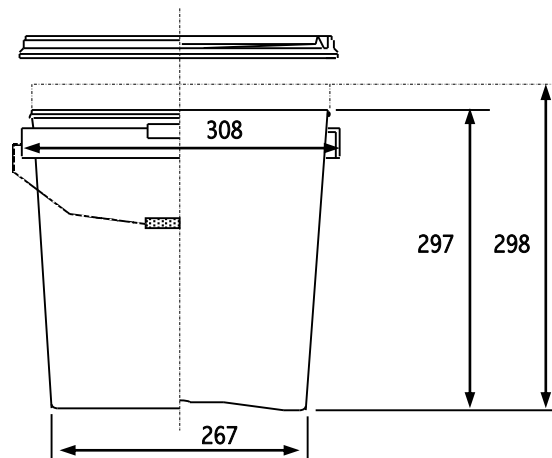

Measurements in millimetres

### GROUPING OF TRANSPORT:

Buckets:	360 buckets per pallet
Pallet dimensions:	1232 x 950 x 1705 (see drawing)
Lids:	60 lids per bag, this serves as a packaging of transportation
Bag dimension:	∅ 310 x 725

